



1665

WHY RAMEX FOAMER › PERCHÈ UN SCHIUMOGENO RAMEX

■ SAVE TIME	■ RISPARMIO DI TEMPO
■ SAVE MONEY	■ RISPARMIO DI DENARO
■ TOP QUALITY MATERIALS	■ MATERIALI DI ALTA QUALITÀ
■ VANGUARD TECHNOLOGY	■ TECNOLOGIA ALL'AVANGUARDIA
■ EFFICIENCY IN DAILY WORK	■ EFFICIENZA NEL LAVORO QUOTIDIANO
■ 100% MADE IN ITALY	■ MADE IN ITALY 100%

WHERE TO USE › DOVE UTILIZZARLO



PROPER USE › CORRETTO UTILIZZO

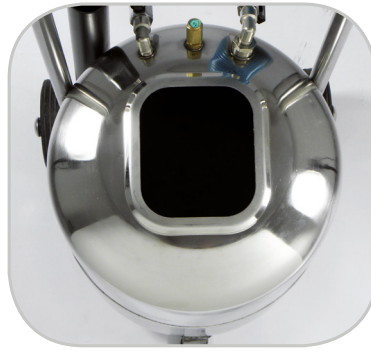

1



2



3



5



4

video





1665



TECHNICAL FEATURES › CARATTERISTICHE TECNICHE

1665 AISI 304

Weight Peso	17 kg
Packing size Dimensione imballo	450x450x1000 mm
Capacity Capacità liquido	36 lt
Working Pressure Pressione utilizzo	58.0 psi / 4 bar
Maximum air inlet pressure Massima pressione aria in ingresso	72.5 psi / 5 bar
Tank material Materiali costruttivi serbatoio	AISI 304
Small parts material Materiali costruttivi minuteria varia	ST/ST plated brass INOX Ottone nichelato
Included Accessories Accessori inclusi	Lance 7070 + PU hose L=32.8 ft plated brass fittings. Without level indicator. Lancia 7070 ingresso ottone nichelato. Tubo PU L=10 mt con raccordi ottone nichelato. Senza indicatore di livello.

1665 PA

Weight Peso	17 kg
Packing size Dimensione imballo	450x450x1000 mm
Capacity Capacità liquido	36 lt
Working Pressure Pressione utilizzo	58.0 psi / 4 bar
Maximum air inlet pressure Massima pressione aria in ingresso	72.5 psi / 5 bar
Tank material Materiali costruttivi serbatoio	AISI 304 Passivation treatment Passivato
Small parts material Materiali costruttivi minuteria varia	ST/ST plated brass INOX Ottone nichelato
Included Accessories Accessori inclusi	Lance 7070 + PU hose L=32.8 ft plated brass fittings. Without level indicator. Lancia 7070 ingresso ottone nichelato. Tubo PU L=10 mt con raccordi ottone nichelato. Senza indicatore di livello.

1665 AISI 316

Weight Peso	17 kg
Packing size Dimensione imballo	450x450x1000 mm
Capacity Capacità liquido	36 lt
Working Pressure Pressione utilizzo	58.0 psi / 4 bar
Maximum air inlet pressure Massima pressione aria in ingresso	72.5 psi / 5 bar
Tank material Materiali costruttivi serbatoio	AISI 316
Small parts material Materiali costruttivi minuteria varia	AISI 316 / AISI 303 Plated brass Ottone nichelato
Included Accessories Accessori inclusi	Lance 7070 + plain hose L=16.4 ft stainless steel fittings. Without level indicator. Lancia 7070 ingresso AISI 316. Tubo liscio L=5 mt con raccordi AISI 316. Senza indicatore di livello.

1665 FE

Weight Peso	17 kg
Packing size Dimensione imballo	450x450x1000 mm
Capacity Capacità liquido	36 lt
Working Pressure Pressione utilizzo	58.0 psi / 4 bar
Maximum air inlet pressure Massima pressione aria in ingresso	72.5 psi / 5 bar
Tank material Materiali costruttivi serbatoio	Powder coating steel Acciaio al carbonio verniciato a polvere
Small parts material Materiali costruttivi minuteria varia	ST/ST plated brass INOX Ottone nichelato
Included Accessories Accessori inclusi	Lance 7070 + PU hose L=32.8 ft plated brass fittings. Without level indicator. Lancia 7070 ingresso ottone nichelato. Tubo PU L=10 mt con raccordi ottone nichelato. Senza indicatore di livello.

Salme



1665

TECHNICAL FEATURES › CARATTERISTICHE TECNICHE

1665 CA

Weight Peso	17 kg
Packing size Dimensione imballo	450x450x1000 mm
Capacity Capacità liquido	36 lt
Working Pressure Pressione utilizzo	58.0 psi / 4 bar
Maximum air inlet pressure Massima pressione aria in ingresso	72.5 psi / 5 bar
Tank material Materiali costruttivi serbatoio	Cataphoric treatment steel Acciaio al carbonio verniciato con cataforesi
Small parts material Materiali costruttivi minuteria varia	ST/ST plated brass INOX Ottone nichelato
Included Accessories Accessori inclusi	Lance 7070 + PU hose L=32.8 ft plated brass fittings. Without level indicator. Lancia 7070 ingresso ottone nichelato. Tubo PU L=10 mt con raccordi ottone nichelato. Senza indicatore di livello.

SAFETY INFORMATIONS › INFORMAZIONI DI SICUREZZA

- The authorized person shall be obliged to check the compatibility of the liquid to be sprinkled with the materials used in the construction of the device .
 - The fluids of the Group 1 (Directive 2014/68 / EU) **can't be use** in any models.
 - The personnel carrying out any work and installation must possess technical expertise and be provided with adequate working tools used in professional environments suitable.
 - The people who work on the product must be protected by appropriate personal protective equipment, in line with the provisions of the laws of individual states.
 - Use the foam only to applications defined by the manufacturer. The Improper use can result in risks to the health and safety of people and property damage.
 - The uses are those provided by the manufacturer industrial and professional, for which the product was developed.
 - Execution of maintenance, inspection and repair, can only be carried out by an expert maintenance technician aware of the dangerous conditions. E 'therefore necessary to provide procedures related to the complete machine designed to handle dangerous situations that may arise and the methods to prevent them. The maintainer must always work with extreme caution with the utmost care and strictly observe the safety rules.
 - During operation, use only the clothing and / or personal protective equipment may be indicated in the instructions for use provided by the manufacturer and those required by the laws in force in each State in the field of safety at work.
 - Do not dump polluting materials into the environment. please do so in compliance with the laws in force in each State.
- *La persona autorizzata deve controllare preventivamente la compatibilità dei liquidi che dovranno essere cosparsi con i materiali utilizzati nella costruzione dell'apparecchio.*
 - **Non si posso utilizzare** fluidi del gruppo 1 (Direttiva 2014/68/UE) in nessun modello di nebulizzatore o schiumogeno.
 - *Il personale che effettua qualsiasi tipo di intervento e installazione deve possedere competenza tecnica ed essere fornito di adeguati strumenti di lavoro professionali utilizzati in ambienti idonei.*
 - *Le persone che operano sul prodotto devono essere protetti da adeguati dispositivi di protezione individuale, in sintonia con quanto previsto dalla legislazione dei singoli Stati.*
 - *Utilizzare lo schiumogeno solo per usi previsti dal costruttore. L'impiego per usi impropri può recare rischi per la salute e la sicurezza delle persone e provocare danni alle cose.*
 - *Gli utilizzi previsti dal costruttore sono quelli industriali e professionali, per i quali il prodotto è stato sviluppato.*
 - *L'esecuzione delle attività di manutenzione, ispezione e riparazione, possono essere svolte solo da un manutentore esperto, consapevole delle condizioni di pericolo. E' quindi necessario prevedere procedure operative relative alla macchina completa atte a gestire le situazioni di pericolo che potrebbero presentarsi e i relativi metodi per prevenirle. Il manutentore esperto deve sempre lavorare con estrema prudenza prestando la massima attenzione e rispettando scrupolosamente le norme di sicurezza.*
 - *In fase di utilizzo utilizzare solo gli indumenti e/o i dispositivi di protezione individuale indicati eventualmente nelle istruzioni per l'uso fornite dal Costruttore e quelli previsti dalle leggi vigenti nei singoli Stati in materia di sicurezza sul lavoro.*
 - *Non disperdere materiale inquinante nell'ambiente. effettuare lo smaltimento nel rispetto delle leggi vigenti in materia nei singoli Stati.*



1665

EXPLODED VIEW › ESPLOSO

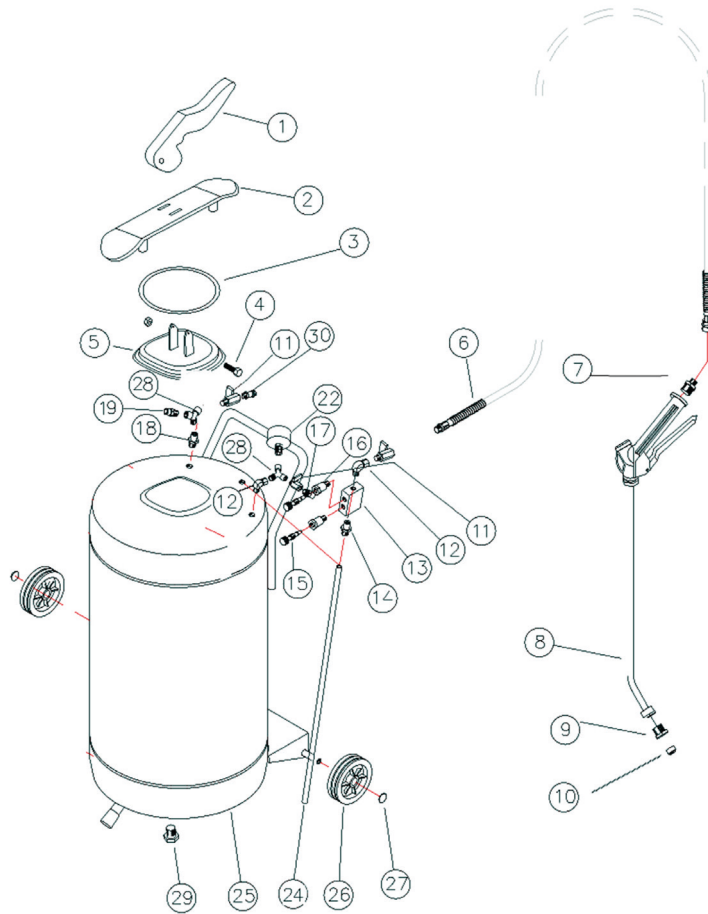

POS	Description and quantity / Descrizione e quantità		Material / Materiale	
1	Lever for plug / Leva per tappo	Complete plug Tappo completo	Stainless steel / Acciaio Inox	
2	Backplate for plug / Contropiastra per tappo		Stainless steel / Acciaio Inox	
3	OR for plug / OR per tappo		Viton	
4	Screw for plug / Vite per tappo		Stainless steel / Acciaio Inox	
5	Plug / Tappo		Stainless steel / Acciaio Inox	
6	Hose / Tubo		Polyurethane / Poliuretano	KIT PU
7	Adapter / Raccordo		Nickel plated Brass / Ottone nichelato	
8 + 9 + 10	Lance / Lancia		Stainless Steel + POM / Acciaio + POM	7070
9	Nozzle holder / Portaugello		POM	
10	Nozzle / Ugello		POM	7004
11	Tap / Rubinetto (2x)		Nickel plated Brass / Ottone nichelato	
12	Bend / Curva		Nickel plated Brass / Ottone nichelato	
13	Foaming box / Blocchetto schiuma	Foaming box Blocchetto schiuma	Stainless steel / Acciaio Inox	KIT BS
14	Reducing nipple / Nipplo ridotto		Nickel plated Brass / Ottone nichelato	
15a	Air pin / Pernetto aria		Stainless steel / Acciaio Inox	
15b	Fluid pin / Pernetto prodotto		Stainless steel / Acciaio Inox	
16	Pin holder / Portaperno		Nickel plated Brass / Ottone nichelato	
17	Safety valve / Valvola sicurezza (5 bar)		Brass / Ottone	KIT VS 5
18	Adapter / Riduzione		Nickel plated Brass / Ottone nichelato	
19	Cut off filter / Otturatore		Nickel plated Brass / Ottone nichelato	
22	Gauge / Manometro		Plastic + brass / Plastica + ottone	KIT MRO
24	Suction pipe / Pescante		Stainless steel / Acciaio Inox	KIT AS 24 KIT AS 40
25	Tank / Serbatoio		Stainless steel / Acciaio Inox	
26	Wheel / Ruota		Plastic / Plastica	
27	Wheel stopper / Coppiglia		Galvanized steel / Acciaio zincato	KIT COP
28	Y adapter / Raccordo Y (2x)		Nickel plated Brass / Ottone nichelato	
29	Lower screw / Tappo inferiore		Stainless steel / Acciaio Inox	
30	Air inlet connector / Ingresso		Nickel plated Brass / Ottone nichelato	
31	Air Compressor / Compressore			



1665

DIMENSIONAL DRAWING › DISEGNO DIMENSIONALE

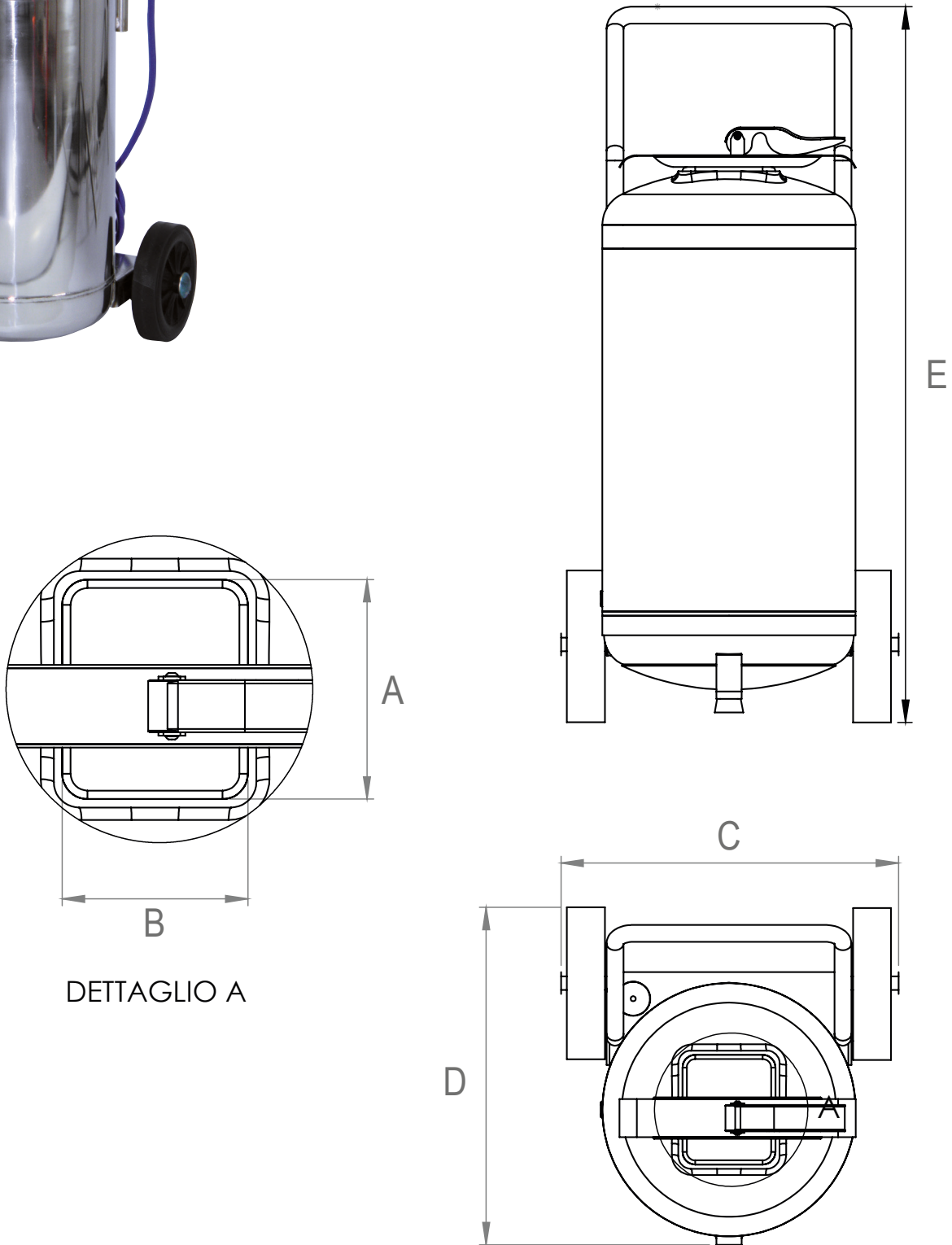

ART.	A	B	C	D	E
1665	130 mm	110 mm	400 mm	400 mm	940 mm







1665

INCLUDED ACCESSORIES › ACCESSORI INCLUSI

FOAMER SCHIUMOGENO	LANCES LANCE		HOSE TUBO
1665	7070		32.8 ft poliurethane hose <i>Tubo poliuretano da 10 mt</i>
1665 PA			
1665 316			
1665 FE			
1665 CA			

OPTIONAL ACCESSORIES › ACCESSORI OPTIONAL

FOAMER SCHIUMOGENO	WHEELS RUOTE	SAFETY VALVE VALVOLA DI SICUREZZA	LEVEL BEND CURVA LIVELLO
1665			
1665 PA			
1665 316			
1665 FE			
1665 CA			

FOAMER SCHIUMOGENO	LANCES LANCE	NOZZLE UGELLO
1665		
1665 PA		
1665 316		
1665 FE		
1665 CA		

HOSE TUBO
61
65
Rilsan™